

Campus Chill Water System Design and Operation Improved Through Hydraulic Modeling With AFT Fathom™

Company: TME Energy Services Division
TME, Inc.
Address: 5800 Evergreen Drive, Suite A
Little Rock, AR 72205-1757
Telephone: 501-666-6776
Fax: 501-663-8888

TME, Inc. is a full service mechanical, electrical and energy engineering firm located in Little Rock, with branch offices in Tulsa and Tucson and provides services to clients in over 25 states. TME Energy Services Division provides a wide assortment of energy related services including utility rate analysis, energy audits, wholesale purchasing of natural gas and electricity, and commissioning.

Reducing energy costs is an increasingly important consideration for plant owner/operators with an excellent example being the energy intensive district cooling system serving the University of Arkansas at Fayetteville. This campus wide system provides air conditioning for 59 buildings along with refrigeration heat rejection for laboratories and laser systems cooling.

Classified as a primary/secondary/tertiary pump system, the primary circuit circulates water within the chiller plants, the secondary system distributes cooling water from the plants to the buildings and other users and the tertiary system consists of pumps within the various buildings. With a total connected load of 13,600 cooling tons, the system includes a Main Chiller Plant with a pumping capacity of 15,000 gpm, a Southwest Chiller Plant with 9,000 gpm capacity and a North Chiller Plant with a capacity of 6,000 gpm. As is the case with many growing universities, UAF was undergoing significant changes that would greatly impact the district cooling system.

In addition to campus load growth, it was desired to evaluate changes to reduce pumping energy costs that would result from supplying colder chilled water to the campus buildings, converting the buildings to variable flow using variable speed pump drives and eliminating the 'decoupler' at each building allowing it to take advantage of available differential pressure in the secondary system. These changes were cumulatively referred to as the "Low Flow/High Delta-T" project. Finally, an operating strategy for the chiller plants to minimize pumping energy was developed. No mean feat given the complexity of this system.

Annual energy savings of 1.9 million KWHr and \$67,000 in pumping power, and \$1,200,000 in annual chiller electrical and gas energy savings.

To answer these questions a model of the district cooling system was developed within AFT Fathom. In addition to the ability to model complex and large networks (the model contains over 3,400 pipes and junctions), unique capabilities provided by AFT Fathom were critical to the success of the study.

Air conditioning load calculations were developed for average and peak demand periods during winter and summer. Cooling load data was then converted into flow demands for the many heat exchangers in the system. Modifying the input for 358 pumps and control valves over the many different load cases studied was greatly facilitated by using AFT Fathom's Excel™ data import capability.

As James Hess, TME Energy Engineer comments,

"Now that we had a method for quickly making changes to the models, the real fun began." A series of runs were made with varying loads, operating configurations, pump characteristics and piping changes.

In the end, the hydraulic model and results achieved by the study were viewed very favorably by the University. Benefits derived from the hydraulic modeling include:

- Instill confidence in the method as the baseline model accurately reflected key operating characteristics of the actual system.
- Confirm selection of the pumps for the Main Plant retrofit.
- Evaluated piping changes in various buildings to achieve significantly improved delta-T thereby lowering required flow rates.
- Verify the energy savings benefit that would result from the "Low Flow/High Delta T" project.
- Identify potential bottlenecks to target areas of improvement.
- Determine that operation of the steam turbine driven North Chiller plant as a 'booster' pump could be eliminated realizing substantial energy savings.
- Provide the University insight into how to best operate the plants from a pumping energy consumption standpoint.
- Annual energy savings of 1.9 million KWHr and \$67,000 in pumping power, and \$1,200,000 in annual chiller electrical and gas energy savings.

"Overall, we were quite pleased with what we were able to accomplish using the AFT Fathom software in this project.", stated Mr. Hess.

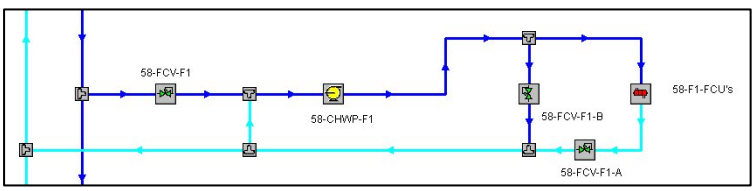
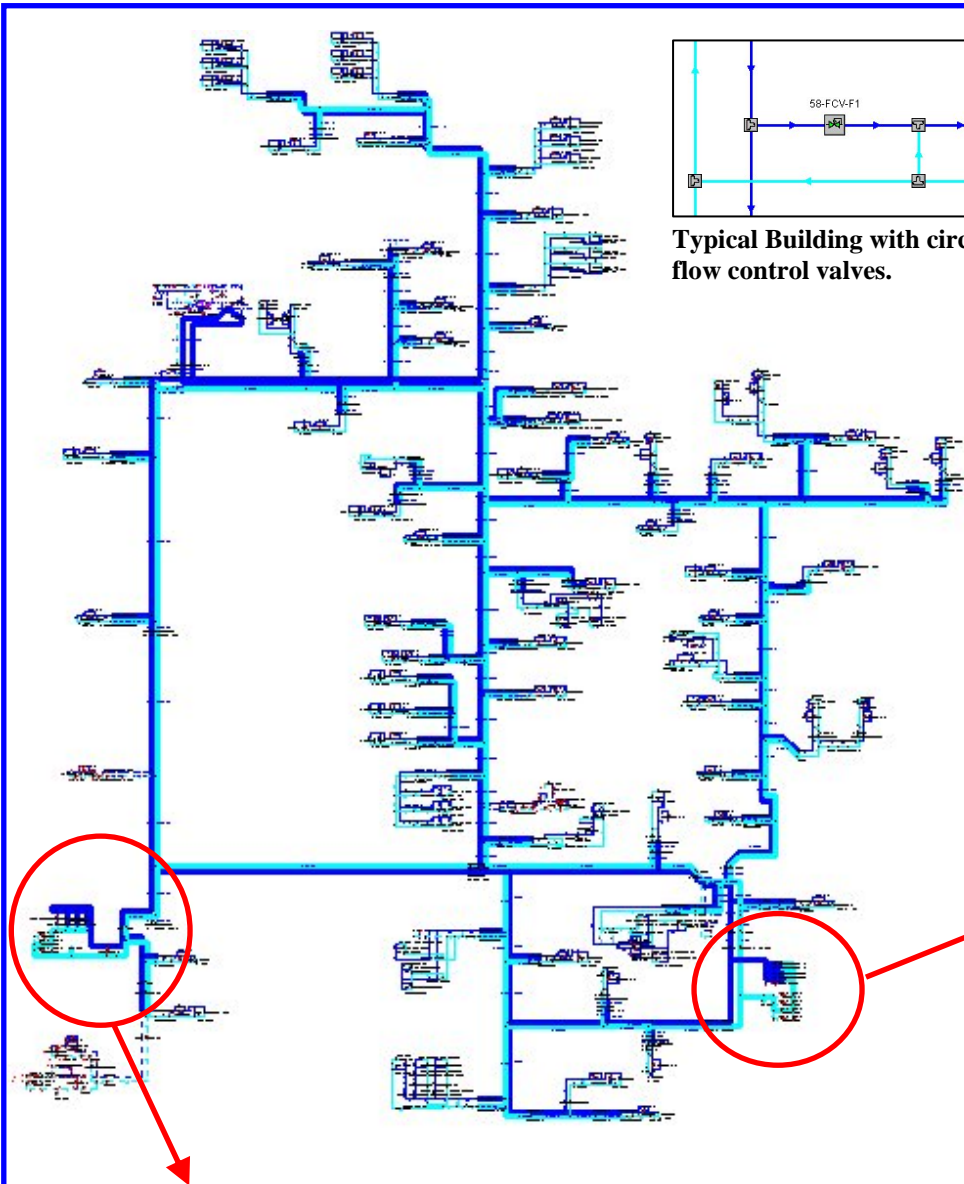

Typical Building with circulating pump, heat exchanger and flow control valves.

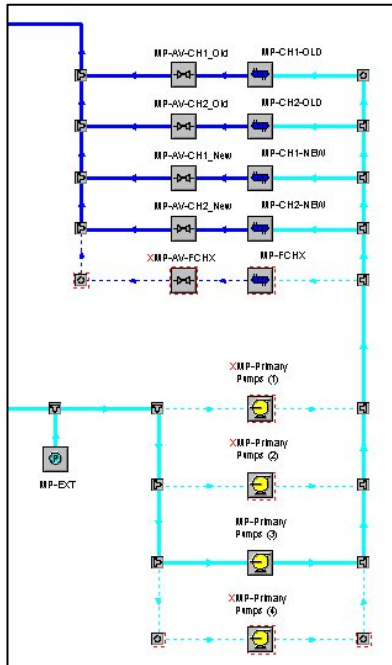

Main Chiller Plant

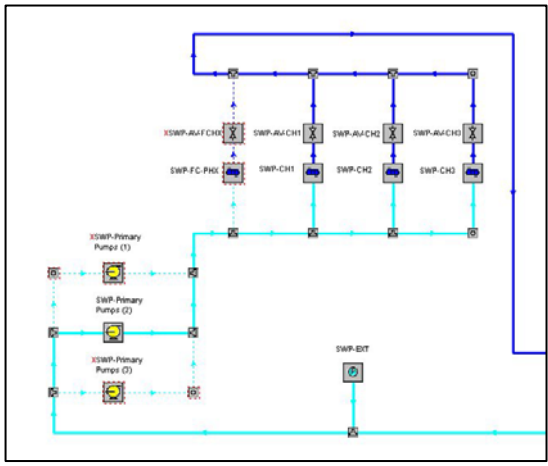

Southwest Chiller Plant

University of Arkansas at Fayetteville
Chilled Water System AFT Fathom