

Cutting Costs in Pump and Pipe Sizing

Combining proven technologies to create a new tool

By Trey Walters, P.E.

You specified your piping system and identified pumps that will do the job. The job is finished, right?

In the past, the answer would have been "yes." But a new design technology allows engineers to do much better. By bringing cost data directly into the pipe-and-pump-sizing process and accessing a new intelligent piping system design technology, plants can achieve a more cost-effective design.

How much more effective? Recent applications at a major chemical company showed first cost reductions averaging 10 percent and as high as 17 percent, and life-cycle cost reductions averaging 50 percent and exceeding 70 percent in one case.¹

Combining technologies

The technology that accomplishes this is, in reality, two mature technologies that were recently combined.² The first technology is one that is familiar to most piping system engineers — pipe network simulation software. Computer programs to calculate pressure drop and flow distribution in pipe networks have been available for more than 30 years. Some companies still rely on in-house developed programs and spreadsheets, while others choose PC-based commercial software. No matter what the form, these

modeling tools allow engineers to evaluate the performance of complex piping systems before any hardware is purchased.

The second technology — numerical optimization — is less familiar to piping system engineers. Numerical optimization methods take an engineer's design and change it to effect improvements such as reduced costs. Such methods have been available for more than 40 years, and have matured into standard usage in a number of industries.^{3,4}

By combining these two technolo-

This energy generation is costly to industry and impacts the environment considerably.

When used to minimize the life-cycle cost of newly designed pumping systems, the new optimization technology can significantly reduce cost and industrial energy usage.

Analysis vs. design

It is often assumed that an experienced piping system engineer can use analysis to reach a good design. And this is true if the engineer defines a good design as

one that just functions properly. However, if the engineer wants to attain the lowest-cost design, he or she likely will get bogged down in the billions of potential design parameter combinations that exist in even simple piping systems.

It might be helpful to distinguish between the related engineering activities of

analysis and design. Engineering analysis is a process in which an engineer specifies a system and then uses software, a spreadsheet or hand calculations to evaluate the system. If the results are not acceptable, the engineer modifies and re-analyzes the system, repeating this process until an acceptable design results. To analyze a system, therefore, the engineer first must specify the system.

Table 1. Comparison of Engineering Analysis and Design

Activity	Input	Output
Analysis	Pipe sizes, pump data, fittings, etc.	Flow rate, velocity, pressure drop, NPSHa, etc.
Design	Required flow rate, velocity, pressure, NPSHr, etc.	Pipe sizes, pump data, fittings, etc.

gies, engineers can create an automated and intelligent way to search for low-cost designs. This capability takes on even greater significance in today's competitive environment and its compressed project schedules and tight budgets.

Recent studies have shown that pumps consume approximately 20 percent of the world's electrical energy.^{5,6}

Engineering design, on the other hand, is the process of determining what the system should be. The output from analysis is the performance of a given system. The output of design is the system itself.

The differences can be further clarified by looking at the inputs and outputs. Table 1 compares these differences for piping system engineering. In piping system analysis, the engineer specifies as inputs the pipe sizes, pump sizes and components and equipment. The outputs consist of performance parameters such as flow rates, pressures, velocities and net positive suction head available (NPSHa). For piping system design, the inputs are the required flow rates, pressures, velocities and net positive suction head required (NPSHr). The outputs are the pipe sizes, pump sizes and fittings.

To get the lowest-cost design, chemical plants need an intelligent way to search for these designs among the billions of possibilities, thereby augmenting the expertise of the piping system engineer. Piping

system optimization offers such a method.

How does it work?

Fig. 1 shows the logical structure of a piping system optimizer.^{7,8} The piping

“To get the lowest-cost design, chemical plants need an intelligent way to search for these designs among the billions of possibilities.”

system layout and design requirements are specified in the input area of the user interface. Data for piping costs are assigned. Such data can be rough

estimates (e.g., steel pipe costs X number of dollars per pound) or detailed estimates in which the costs per length for different pipe sizes are entered.

After the user interface comes the hydraulic solver. This consists of conventional pipe network analysis algorithms. Here, the initial piping system design is solved hydraulically.

If this were an analysis, the hydraulic results — the flow rates, pressures and velocities — would be passed back immediately to the user as output. But something different happens here. The hydraulic results are instead passed to the optimizer, which modifies the original design and passes it back to the hydraulic solver. The hydraulic solver provides a hydraulic solution to the modified design. The hydraulic solver functions similarly to a subroutine, which the optimizer calls repeatedly after making design modifications. This allows a sequence of designs to be intelligently evaluated and compared.

After the Optimizer determines that no further design improvements are possible, it returns the optimal design to the user as output.

The most efficient optimization algorithms are gradient-based search methods.^{9, 10, 11, 12} These methods evaluate the complex interaction of design parameters and identify the combinations of parameters that yield the lowest cost. If the system is small enough, genetic algorithm methods can be used. The use of genetic algorithm methods in conjunction with gradient-based methods is advantageous in some cases. A comparison of these methods for piping system design is given by a company's user's guide.¹³

The “sweet spot”

Every piping system with at least one pump has a “sweet spot” — the optimal tradeoff in pipe, pump and, optionally, energy and maintenance costs. This also

Figure 1. Logical Structure of a Piping System Optimizer

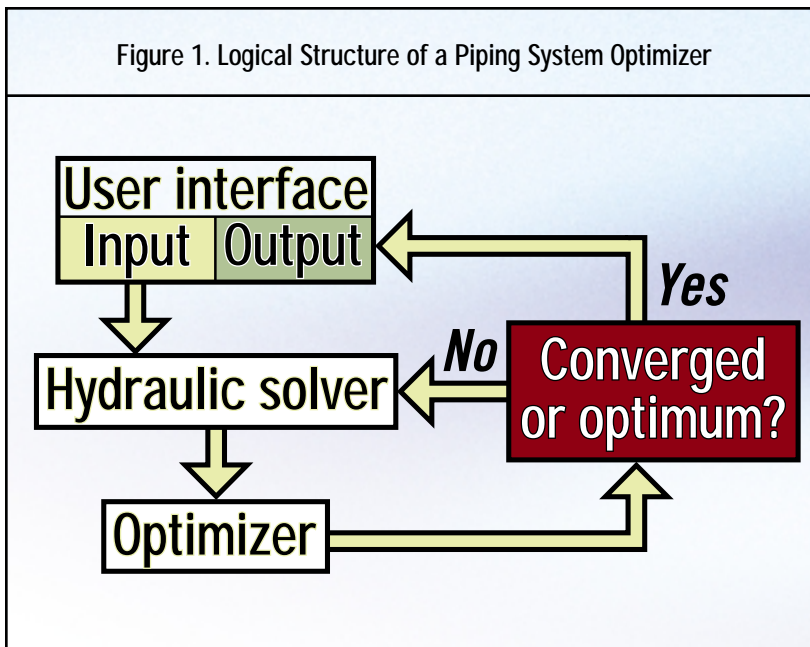

The piping system layout and design requirements are specified in the input area of the user interface.

is referred to as the optimal pumping system operating point, or OPSOP.¹⁴

If a system's pump is sized away from the system's sweet spot, the system will cost more than is necessary to meet the design requirements. And once the piping system is specified and installed, most opportunities for cost reductions are lost forever.

Therefore, it is important for the engineer to find the sweet spot before committing to hardware. Unfortunately, conventional design methods cannot do this. However, a piping system optimization design tool can accomplish this feat.

Putting the tool to the test

A typical cooling system is shown in Fig. 2. In this case, the design requirement is to supply 15,000 gallons per minute (gpm) to each condenser and 700 gpm to each lube oil cooler. When all combinations of potential pipe sizes are considered, the size of the search space grows exponentially.

For example, the system shown in Fig. 2 has more than 40 quadrillion design possibilities. Obviously, it is not practical for even an experienced designer to look at even a fraction of these possibilities.

Using steel pipe with standard costs and cost data for pumps, the piping system optimizer can identify the sweet spot from among all the potential designs. Fig. 3 shows the costs for optimal designs with different pump head rise and power usage values for a 10-year life-cycle design.

Although the piping system optimizer can find the sweet spot in a single run, the graph helps show the impact of different pump selections. Keep in mind that Fig. 3 shows only optimized designs, representing the lowest-possible cost systems that meet the design requirements. Traditional methods do not find such optimums; therefore, they will cost significantly more.

The cost data can be nonrecurring or recurring (e.g., energy use over time), allowing optimization to be performed for first or life-cycle cost. Table 2 shows a cost comparison of optimization runs in which the goal was to

minimize first cost and 10-year life-cycle cost of the cooling system. It can be seen that an optimal life-cycle design would save \$2 million over 10 years, but would require an initial design that costs \$400,000 more.

First or life-cycle cost?

The decision on whether to optimize for

minimum first cost or life-cycle cost can be difficult, and is frequently driven by other business considerations. However, a piping system optimization tool can make this decision easier.

Once a case has been set up to minimize the first cost, the additional effort to optimize for life-cycle cost is minimal. With results in hand for low

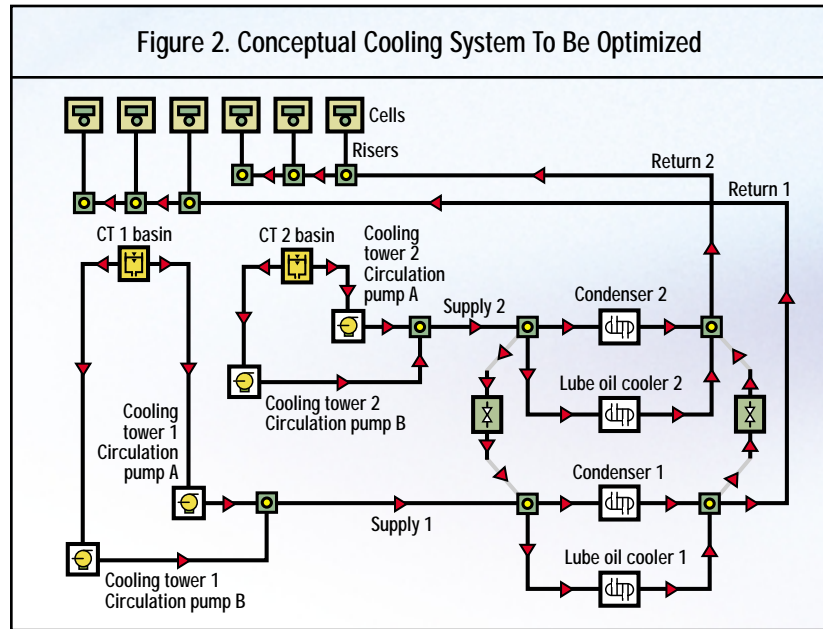

For the cooling system shown here, the design requirement is to supply 15,000 gpm to each condenser and 700 gpm to each lube oil cooler.

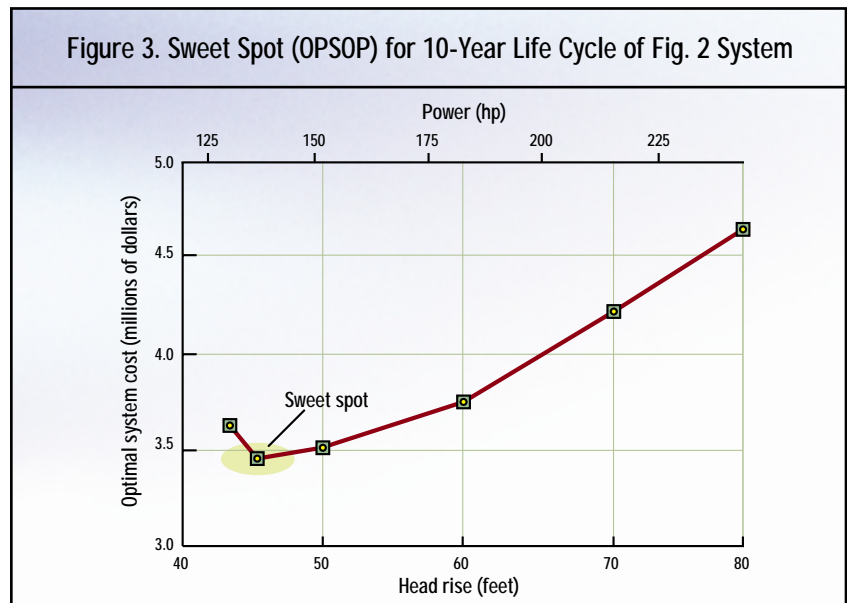

Using cost data, the piping system optimizer can identify the sweet spot among all potential designs.

Table 2. Comparison of Initial and 10-Year Life-Cycle Costs (in U.S. dollars, for system shown in Fig. 2)

Criteria	Material	Installation	Initial Material + Installation	Operating	Total
Initial cost	\$376,000	\$546,000	\$923,000	\$4,703,000	\$5,625,000
Life-cycle cost	\$448,000	\$920,000	\$1,368,000	\$2,210,000	\$3,578,000

first-cost designs and low life-cycle cost designs of different design lifetimes, decision-makers will have more information with which to make the best choice.

Designing for multiple scenarios

Another powerful capability of a piping system optimizer is the ability to intelligently size the system for multiple design cases. These cases could be, for example, normal and standby operation, different load requirements between summer and winter, and multiple pump-duty points. Multiple design case requirements are included as additional design constraints, and the optimum design is found to satisfy all design cases for the lowest cost.

Adding margin to designs

One occasional negative comment about piping system optimization is that it removes margin from the design and thus leaves no room for growth in the installed system. This is a misconception.

When using traditional design methods, margin comes from one of two sources. The first is an intentional margin that is included in the design requirements. The second is an unintentional margin that is a byproduct of the imperfect design methods in common use.

Unintentional margin is not quantifiable and is randomly spread around the system. One part of the system might have a 5 percent margin (and possibly even a negative margin) while another part has a 40 percent margin.

By using piping system optimization engineers can reduce the unintentional margin to zero; therefore, all margin is intentional. With optimization, the

design margin can be assigned as desired around the system.

With a piping system optimizer, the engineer also can ask questions that previously went unasked. For example, if the engineer wanted to design with a 30 percent margin, the impact on first cost and life-cycle cost could be quantified and compared to designs of 0 percent, 10 percent and 20 percent margins. With this information in hand, the plant might decide that a 30 percent margin is too expensive, and opt for a different margin.

A final thought

It is important to note that new engineering design tools rarely, if ever, can replace engineers. Instead, engineers use the new

tools to produce higher-quality designs within budget and time constraints.

Piping system optimization is simply a tool that helps engineers do their jobs better than they could before. It frees up some of the time spent on the manual aspects of piping-system design, allowing engineers to focus on creative alternatives to company problems.

In the author's opinion, computer software will never replace the human engineer. It just makes the engineer better equipped — and more necessary than ever.

Walters is president and director of software development at Applied Flow Technology Corp., Woodland Park, Colo. He can be reached at treywalters@aft.com.

References

- Hodgson, J. and T. Walters. "Optimizing Pumping Systems to Reduce First or Life-Cycle Cost." *Proceedings of the 19th International Pump Users Symposium*, Houston, February 2002.
- Applied Flow Technology. *AFT Mercury 5.0 User's Guide*, Woodland Park, Colo., 2001.
- Schmit, L. A. "Structural Design by Systematic Synthesis." *Proceedings of the 2nd Conference on Electronic Computation*, American Society of Civil Engineers, New York, 1960, pp. 105-122.
- Vanderplaats, G. N. "Structural Design Optimization — Status and Direction." *AIAA Journal Aircraft*, 1999, Vol. 13, No. 1, pp. 11-20.
- Frenning, L. et al. *Pump Life Cycle Costs: A Guide to LCC Analysis for Pumping Systems*, Hydraulic Institute and Europump, Parsippany, N.J., 2001.
- Hovstadius, G. "The Real Price of Pumping." *Pumps and Systems*, Randall Publishing, January 2002, pp. 6-7.
- Hodgson, J. and T. Walters, February 2002.
- Applied Flow Technology, 2001.
- Hodgson, J. and T. Walters, February 2002.
- Applied Flow Technology, 2001.
- Vanderplaats, G. N., 1999.
- Vanderplaats, G. N. *Numerical Optimization Techniques for Engineering Design*, 3rd Ed., Vanderplaats Research & Development Inc., Colorado Springs, Colo., 1999.
- Applied Flow Technology, 2001.
- Hodgson, J. and T. Walters, February 2002.