

Cooling System Surge Analysis with AFT Impulse™

Company: Chicago Bridge & Iron
Process Engineering Division
Address: 14105 South Route 59
 Plainfield, IL 60544
Telephone: 815-439-6303

Chicago Bridge & Iron Company, with more than 60 locations and approximately 11,000 employees, is a leading engineering, procurement and construction company, specializing in lump-sum turnkey projects for customers that produce, process, store and distribute the world's natural resources.

Chicago Bridge & Iron's Process Engineering Division was tasked with developing the design for a gasification system serving an LNG off-loading terminal. An innovative and energy efficient approach was taken utilizing waste heat from a nearby power plant. A key criterion in the design was to insure the new, interconnecting system did not compromise the mechanical integrity or operation of the plant cooling system.

A previous analysis resulted in a design incorporating check valves, flow control valves, booster pump bypass valves and full voltage booster pumps. While meeting some of the design criteria, an analysis of the system using AFT Impulse revealed vacuum conditions would exist in the piping under various operational scenarios, including pump trip. As information was not available on the vacuum capabilities of the existing piping, a new system design was developed to eliminate these possible problem areas.

The AFT Impulse model consisted of both the existing cooling water system and the new, interconnecting system flowing in excess of 108,000 gpm. The existing system included:

- Six cell cooling tower with two vortex breakers
- Two circulating pumps
- Two condensers
- All interconnecting piping, valves, fittings, etc.

Adding to this the new, interconnecting system included;

- Four booster pumps
- Seven plate-frame heat exchangers
- Tower connecting valves
- interconnecting piping, valves, fittings, etc.

One of the first steps was to benchmark the existing system. Running steady-state cases in AFT Impulse, Doug DeGraaf, CBI Senior Engineer, determined discrepancies in predicted and measured parameters was due to differences in the theoretical and actual losses in the condensers due to plugged tubes and fouling. Condenser loss values were adjusted to calibrate the model. As Doug explains; "AFT Impulse allowed the separation of 'reality' from 'theoretical' to arrive at a true model of the existing system."

Several transient cases were studied including tripping combinations of the existing circulating pumps and added booster pumps and closing of the new connecting valves. Dynamic modeling revealed considerable flow would continue after pump trip due to the momentum of the water in the long pipelines. This continued flow after pump trip caused low pressure in the existing cooling tower return lines resulting in reverse flow and air being drawn into these lines.

Initially check valves and other components had been included to avoid such conditions, but AFT Impulse revealed this would result in transient pressures below atmospheric, a situation that needed to be avoided. Using AFT Impulse a revised design was developed that eliminated all of the check valves, bypass valves, flow control valves and made use of variable speed drives for the pumps.

Results of this new design yielded not only a system with no mechanical integrity issues, but also a significant reduction in the system components required and simplified system control.

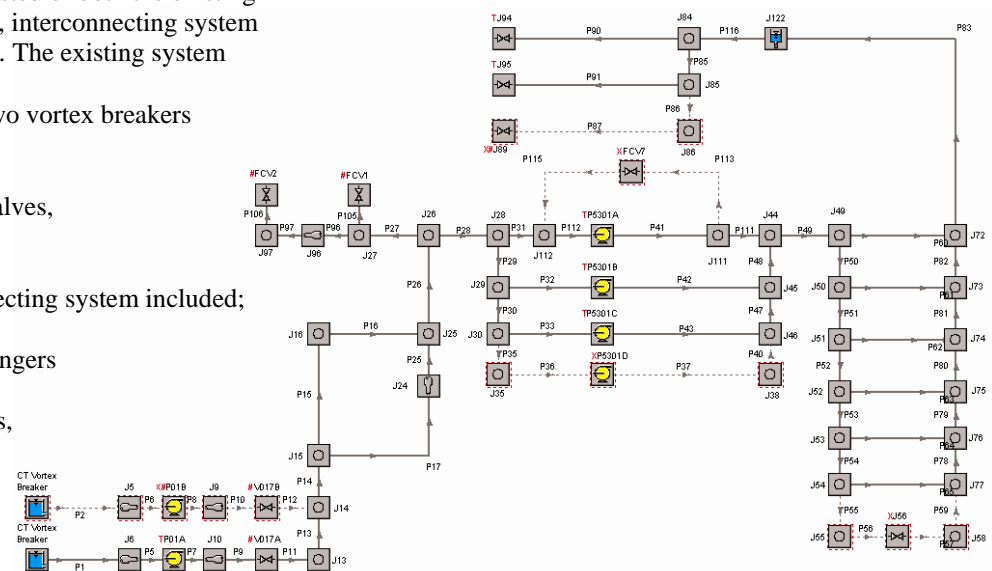

Additional benefits derived from modeling the system with AFT Impulse were development of several recommendations to improve operability. By implementing these recommendations the resulting system will be able to restart quickly after an upset with minimal operational concerns.

Describing his experience using AFT Impulse for this project, Doug stated it; “proved to be both easy to model and easily understandable as it relates to what was actually taking place during valve and pump transients. Program outputs included model input synopsis, graphical output of pressures, flowrates, etc. at any time or place in the model, and steady-state analysis outputs (prior to initiation of transients).”

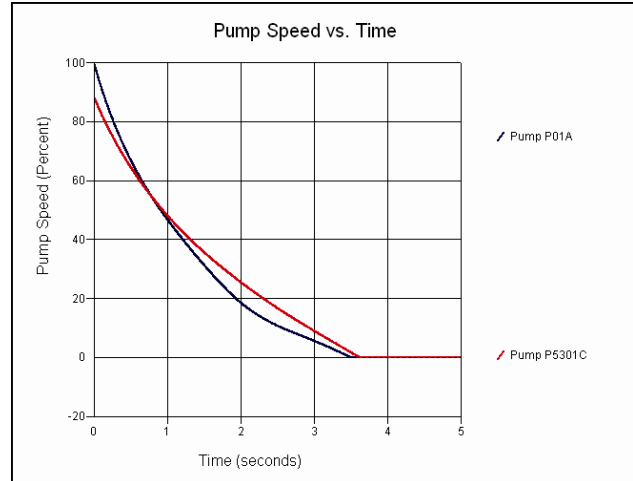

Pump speed vs. time graph for one of the existing circulating pumps and one of the new booster pumps after tripping

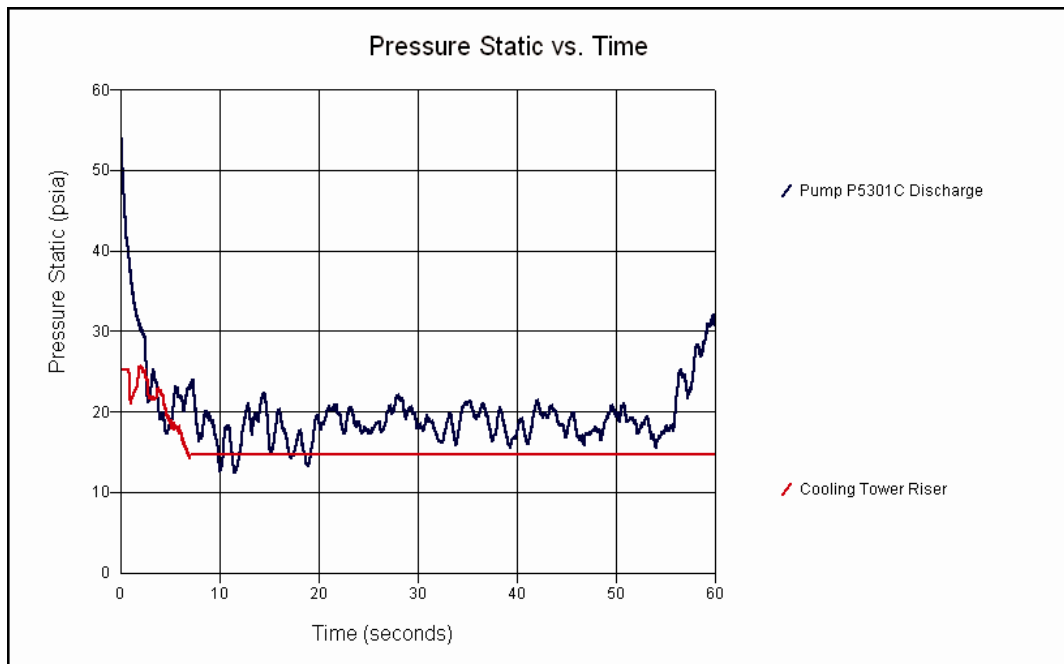

Pressure vs. time graph at pump discharge and inlet of cooling tower riser after pump trip

